

SCALE 1:2

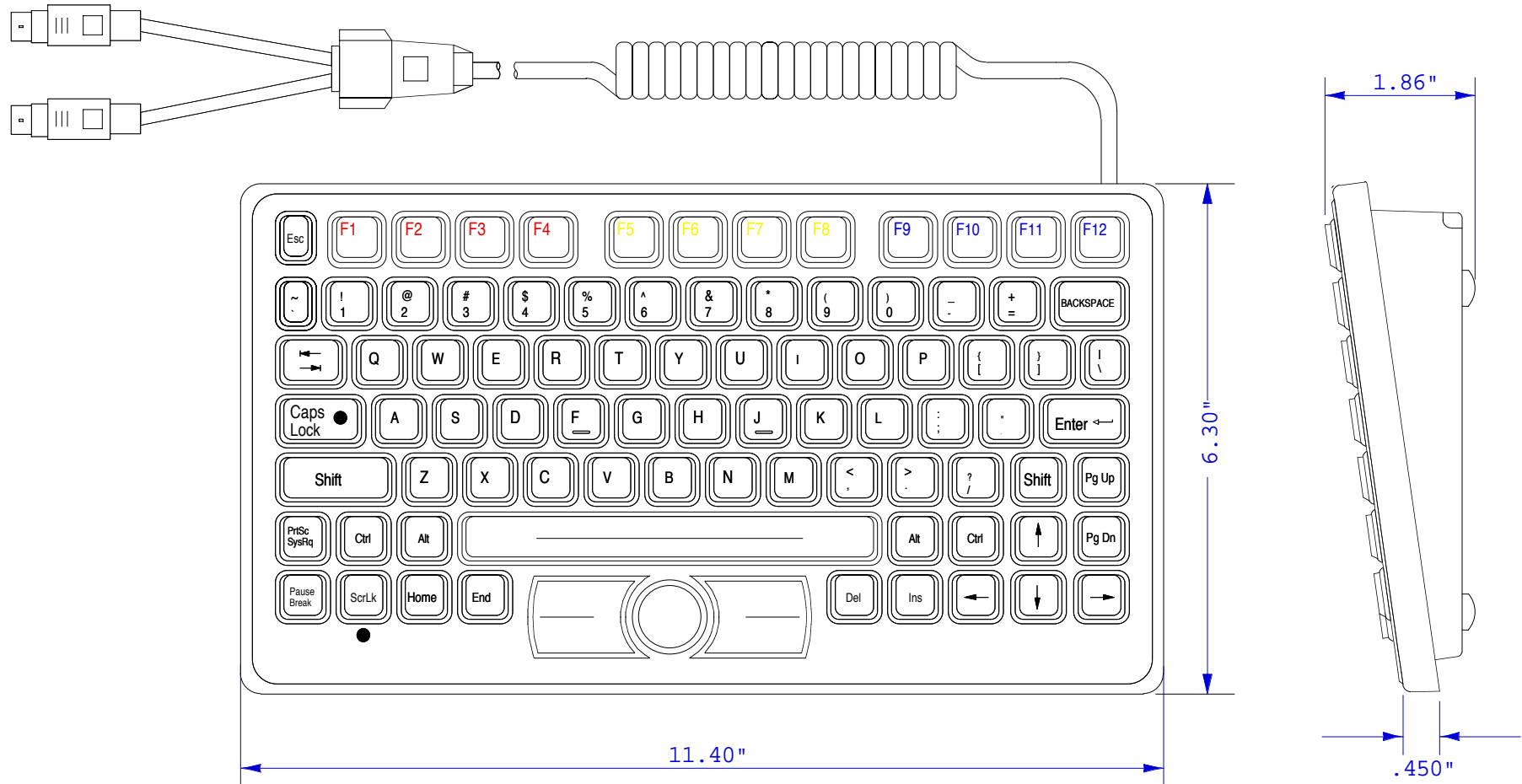

KEY SWITCH

MATERIAL: Industrial Silicone Rubber
LIFE: Greater than 10 million cycles
TRAVEL: 0.055 in.
ACTUATION FORCE: 5 oz. (130g)
FEEDBACK: Tactile with Mechanical Snap

HUMIDITY

80% Humidity Resistant

POWER

KEYBOARD: 5V@20ma (from CPU port)
HULAPOINT: 5V@10ma (from mouse connection port)

FLAMMABILITY

PRINTED CIRCUIT BOARD:
SILICONE OVERLAY:
94HB
INTERFACE CABLE:
94VO

TEMPERATURE

-40 F to +194 F (-40 C to +90 C)

SHOCK

3 X 11 ms pulses of 50g on each of 3 axes

VIBRATION

POWER SPECTRAL DENSITY: .04g/HZ
FREQUENCY RANGE: 20Hz-2Khz
DURATION OF TEST PER AXIS: 3 hours

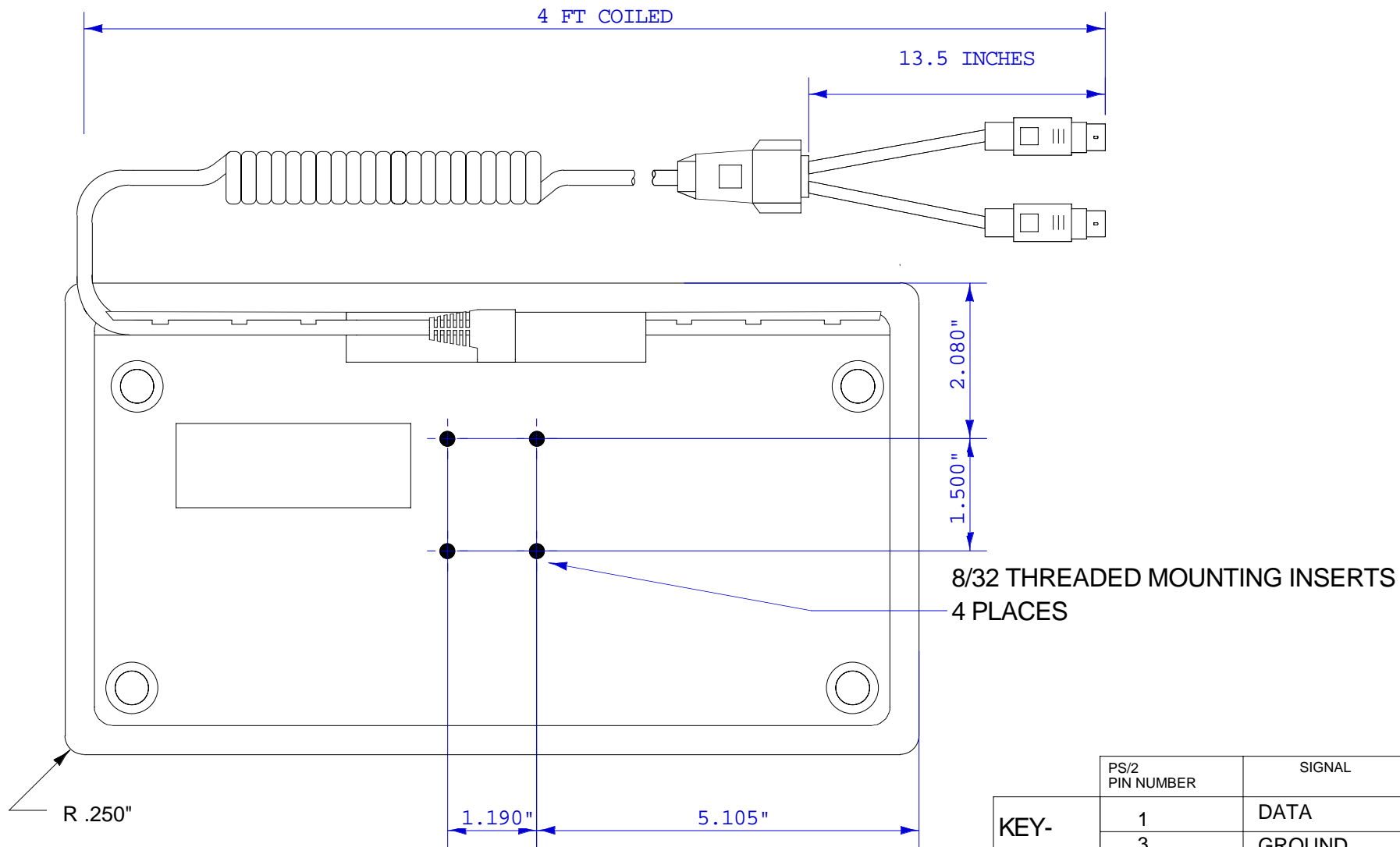

ENCLOSURE FABRICATED FROM :
GE CYCLOLY LG900 PC/ABS/ UV
STABLE OR EQUIVALENT

860-DP -PS/2

	PS/2 PIN NUMBER	SIGNAL
KEY- BOARD (GREY)	1	DATA
	3	GROUND
	4	+5V
	5	CLOCK
MOUSE (BLACK)	1	DATA
	3	GROUND
	4	+5V
	5	CLOCK